

افيكو AFICO

Arabian Fiberglass Insulation Company Ltd.
 J.V. of Zamil Industrial & Owens Corning Corp.

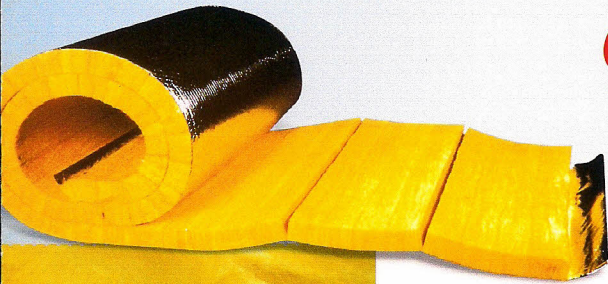

AFICO Pipe Wrap Insulation

Technical Data Sheet
 Product Code: PWI

DESCRIPTION

AFICO Pipe Wrap Insulation consists of a roll of semi-rigid all-purpose fiberglass board insulation composed of fine, stable and uniformly textured inorganic glass fibers bonded together by a non-water soluble and fire-retardant thermosetting and heat resistant resin. It is free from coarse fibers and shot due to its mineral composition.

FACING

AFICO Pipe Wrap Insulation is supplied in semi-rigid roll types with factory-applied vapor retardant white All Service Jacket (ASJ) or Aluminum Foil Glass Reinforced Kraft (FRK) vapor barrier facing. The Fibrous glass insulation is adhered to the jacket

with the end grain of the insulation perpendicular to the jacket surface. This construction provides a product that is flexible and easily wrapped around the pipe or tank, while providing the rigidity necessary for a neat durable installation.

APPLICATION

AFICO Pipe Wrap Insulation is designed for use in industrial and commercial systems as thermal and acoustical insulation for large diameter pipes, round ducts and oval ducts at 250 mm (10") or greater. It can be used to insulate pipe flanges, valves, groups of pipes, pipes with tracing lines, vessels and tanks.

STANDARD AVAILABLE PRODUCTS

AFICO Pipe Wrap Insulation is made in standard 1.0 meter width, packaged in cartons or polybags.

Thickness		Length		Densities	
mm	inch	mm	ft	kg/m ³	lb/ft ³
25	1	8	26	48	3
38	1 ½	6	20		
50	2	4	13		and/or
64	2 ½	2	7		
75	3	2	7	64	4

NOMINAL THERMAL CONDUCTIVITY

(BS 874) (ASTM C 518)

"K" or "λ" value		Mean Temperature	
W/m.°C	Btu.in/hr.ft ² .°F	°C	°F
0.032	0.22	24	75
0.042	0.29	93	200
0.079	0.55	260	500

THERMAL CONDUCTIVITY (ASTM C 177)

Density: 48 and 64 kg/m³

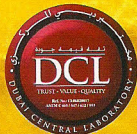
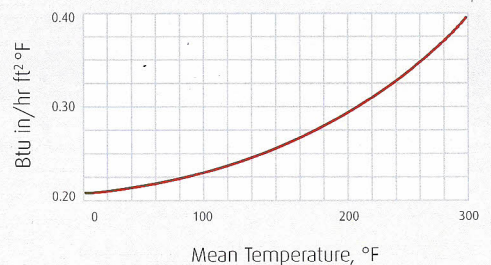

* Standard Products and Sizes

AFICO Pipe Wrap Insulation

Technical Data Sheet

Product Code: **PWI**



Performance & Physical Characteristics

Working Temperature Limitations (ASTM C 411)

-50°C TO 350°C. At excessive temperatures, a limited migration of binder may occur in the insulation in contact with hot surface. This in no way impairs the performance of the insulation.

Alkalinity

pH 9

Corrosiveness (ASTM C 665)

Chemically inert. Will not cause or accelerate corrosion of steel, stainless steel, copper or aluminum, due to its particular inorganic and mineral composition.

Mold Growth (ASTM D 2020, UL 181)

Does not breed or sustain mold, fungus, bacteria or rodents.

Moisture Absorption (ASTM D-07 B, ASTM C 553)

In conditions of 95% relative humidity at 49°C for 96 hours, moisture absorption is less than 0.2% by volume, when tested in accordance with ASTM C 533. **AFICO** fiberglass products do not absorb moisture from the ambient air nor water by capillary attraction, only water under pressure can enter the insulation products but that will quickly dry out owing to the material's open cell structure.

Vapor Permeability (ASTM E 96 A)

FRK	0.02	PERM
ASJ	0.02	PERM

Puncture Resistance (ASTM D 781)

FRK	25	Units
ASJ	50	Units

Compressive Strength (ASTM C 165)

At 10% deformation 125 lb/ft² minimum (Flat Configuration).

Surface Burning Characteristics (UL 723, ASTM E 84, ASTM E 136)

Base glass fiber is non-combustible when tested to ASTM E84.

Facing	Flame Spread	Smoke Developed	Fuel Contributed
FRK	0	0	0
ASJ	5	10	0

Fire Properties

B.S. 476 PART 4 – Non-combustible
B.S. 476 PART 5 – Ignitability
B.S. 476 PART 6 – Fire propagation
B.S. 476 PART 7 – Surface spread of flame
Class 'O' fire rating to the building regulations section E15

Specification Compliance

AFICO Pipe Wrap Insulation complies with the property requirements of the following specifications:

- U.S. Federal Specification HH-I-558, Form B, TYPE I, Class 7.
- U.S. Federal Specification HH-B-100B, TYPE I and II for Vapor Barrier Jackets only.
- ASTM C 795: Standard Specification for wicking-type thermal insulation for use over Austenitic Stainless Steel.
- DCL ASTM - C 533 - C 547 - C 612 - C 665
- CE-EN 13162

Thermal Resistance "R" Value (Excluding Facings) (ASTM C 167)

"R" is a measure of the resistance to heat flow of a material of any given thickness. ("R" = m². °C/W or hr. ft². °F/Btu.)

$$R = \frac{T}{K} \quad \text{where "T" = thickness} \\ \text{and "K" or "λ" = thermal conductivity}$$

Installation

Length of Pipe Wrap to be cut for specific pipe or duct is determined as follows:

$$\begin{aligned} & \text{Pipe/Duct outside diameter} \\ + & \text{ (insulation Thickness x 2)} \\ \times & \text{ pi (3.1416)} \\ + & \text{ 75mm for flange} \end{aligned}$$

$$= \text{Length of pipe wrap to be cut}$$

Use a flap tool or knife to remove a 75mm insulation from one end to make a flange.

Each 1 meter wide section of Pipe Wrap May be secure around the pipe by using staple (on 75mm centers) and mastic, or by applying staples and vapor barrier pressure sensitive tapes. Adjacent section should be butted together and then sealed with vapor barrier tape.

Pipe supports must be from the pipe itself or from high compressive strength insulation such as calcium silicate.

AFICO Pipe Wrap can also be used to insulate groups of pipes, pipe flanges and valves.

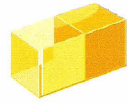

Performance & Physical Characteristics

Typical Applications

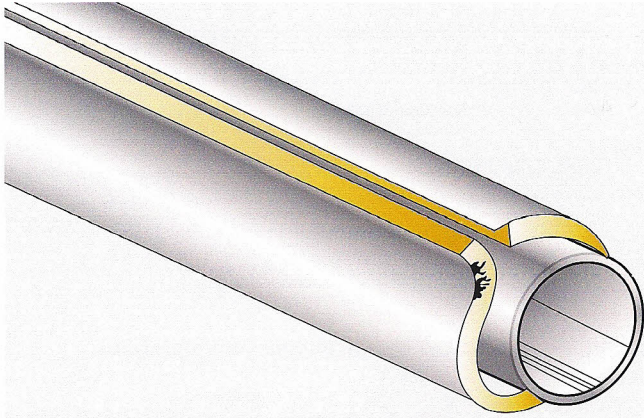

Pipes and Ducts

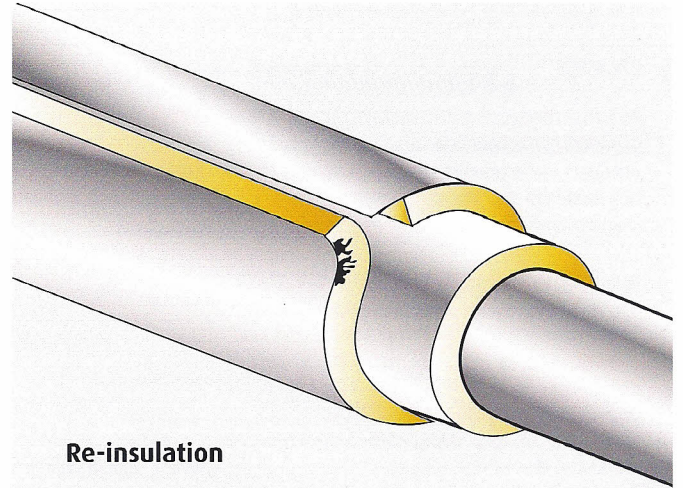

Re-insulation

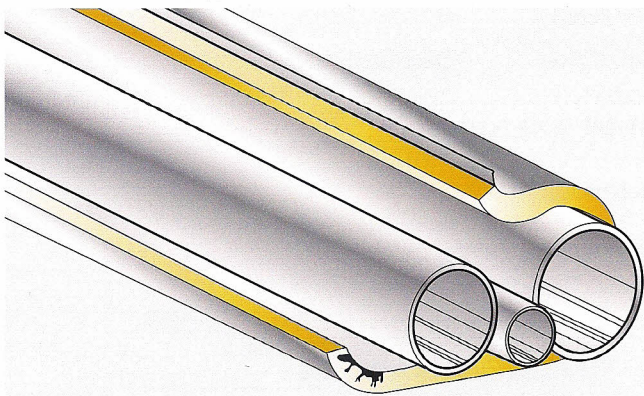

Groups of Parallel Pipes

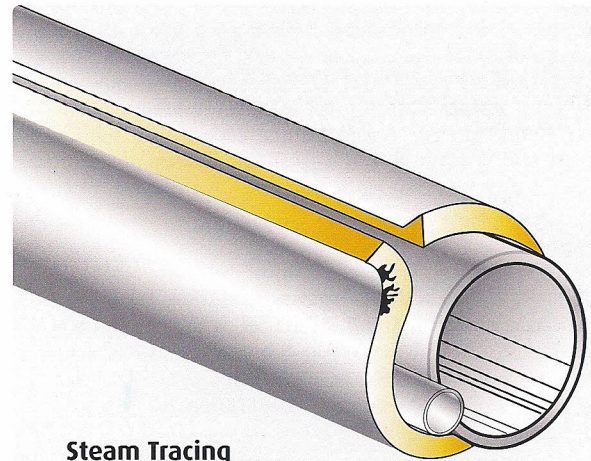

Steam Tracing

Fittings and Valves

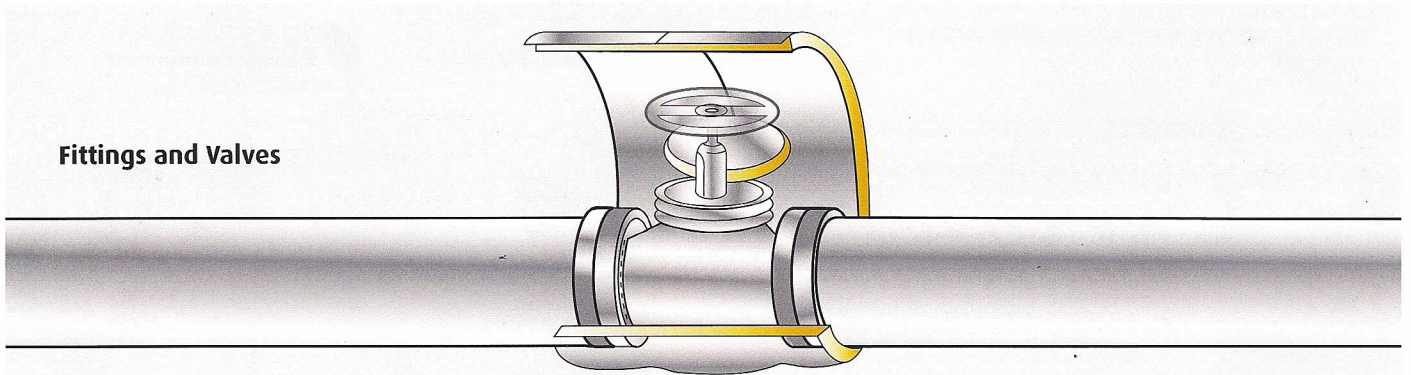



AFICO Pipe Wrap Insulation

Technical Data Sheet
Product Code: **PWI**

MAINTENANCE

No maintenance is required. **AFICO Pipe Wrap Insulation** have a high resistance to accidental damage from knocks and handling during installation and maintenance. Dimensionally stable under varying conditions of temperature and humidity, rot-proof, odourless, non-hygroscopic and will not sustain vermin or fungus due to its inorganic and mineral compositions.

The product will maintain its thermal properties throughout the lifetime of the construction and will not age. **AFICO** fibreglass is non toxic and not hazardous to health.

STORAGE

To avoid moisture in the building construction, **AFICO** insulation products stored outside must be kept dry. We recommend **AFICO** products to be always stored in covered and dry areas. **AFICO** is not liable for the damage resulting from inadequate utilization, loading and off loading and mishandling of its products.

WARRANTY

See manufacturer's General Terms and Conditions of Sale. As **AFICO** and/or OC has no control over installation design, installation workmanship, accessory materials, or conditions of application, **AFICO** and/or OC does not warrant the performance or results of any installation containing their products. This warranty disclaimer includes all implied warranties, including the warranties or merchantability and fitness for a particular purpose.

Arabian Fiberglass Insulation Company **AFICO** reserves the right to alter product specifications without prior notice, as part of its policy of continued development and improvement. The installation methods described in this leaflet are not compulsory. The choice of **AFICO** materials and methods of fixing are the decision of the specifier, consultant or contractor. For further information or advice on specification of **AFICO** products, contact your local sales office.

AVAILABILITY

Manufactured by **Arabian Fiberglass Insulation Company, Ltd.** (AFICO), member of **Zamil Industrial**, with headquarters and production facilities located in Dammam, Saudi Arabia, under license from and utilizing the manufacturing specifications and technology of **Owens-Corning Corporation** (OC), Toledo, Ohio, U.S.A.

Marketed throughout Saudi Arabia, the G.C.C. countries, the Middle East and the Far East. **AFICO** products are available directly from **AFICO** as well as through a vast and reliable network of local distributors.

Special products are manufactured on request.

AFICO PRODUCTS

PRODUCTS CODE

Acoustical Ceiling Panels	ACP
Blanket Insulation	BKT
HD Series Blanket Insulation	HDB
Board Insulation	BD
Roof Insulation	RI
Roof Deck Board Insulation	RD
Cavity Wall Insulation	CWI
Pre-engineered Metal Building Insulation	MBI
Faced Duct Wrap	FDW
Duct Liner	DL
Duct Liner Board	DLB
Mechanical Board Insulation	MBD
Heavy Density Pipe Insulation	PI
Pipe Wrap Insulation	PWI
Thermal Insulating Wool	TIW
Quiet Liner	AQL
Woven Facing	AWF
Prefabricated Duct Board	PDB

For more information call the insulation professionals:



H.O. & Factory: P.O. Box 1289, Dammam 31431, Saudi Arabia
Tel: +966 3 847 2901 / 847 1519
Fax: +966 3 847 3605
E-mail: info@afico.com.sa

Riyadh Office: P.O. Box 50281, Riyadh 11523, Saudi Arabia
Tel: +966 1 472 5555 ext. 283
Fax: +966 1 291 0162
E-mail: info@afico.com.sa

Jeddah office:
Tel:
Fax:
E-mail: info@afico.com.sa

Gulf Regional Office: P.O. Box 44493, Deira, Dubai, U.A.E.
Tel: +971 4 294 1211
Fax: +971 4 294 1168
E-mail: aficogcc@emirates.net.ae

Export Office: P.O. Box 90-284, Jdeidet El Metn Beirut - Lebanon
Tel: +961 1 900962
Fax: +961 1 900963
E-mail: AFICO@cyberia.net.lb



info@afico.com.sa



www.afico.com.sa



Our GREEN promise:
the healthy solution

- ENERGY SAVING
- ENVIRONMENTALLY FRIENDLY
- RECYCLED MATERIALS
- SOLUTION FOR GLOBAL WARMING



AFICO is committed to a greener, cleaner environment. AFICO have responded to this call for conservation by increasing the amounts of recycled materials in our products.

Authorized Distributor